



December 2018

Volume 22, Issue 12

Holiday Party Saturday December 8, 2018

Celebrating another great year of fellowship and flying chips!

Once again will return to the Elks Lodge in Walnut Creek for our annual luncheon. Bring a guest and enjoy the instant gallery, raffle, silent auction and a year in review presentation.

What we need from you:

1. If you have not paid online yet, rsvp at the BAWA website for \$25 per person
2. Consider donating an item for the silent auction
3. Bring one or two items for the turning gallery (no competition just lots of Oohs and Ahhs)
4. Bid, win, laugh and enjoy!

Party time: 11 - 2:30

Location: The Elks Lodge is located at: 1475 Creekside Drive, Walnut Creek, CA 9459

Catered by New Mecca Cafe - Motto - "We cook with pride"



BAWA Holiday Silent Auction

With your help the auction will be great fun and a successful fund-raiser for the club. Please consider making a donation. Some ideas that have been popular include:

- Mentoring/Tutoring (pick a topic you know well and would be of interest to others.)
- Wine or Activity (to do outside of turning - favored by spouses)
- A beautiful piece of figured wood or burl
- Consulting/advice (e.g. building an efficient dust collection system)
- NEW Special Tools or Jig
- Services (e.g. wood stabilization, coring etc.)

Proceeds go to the club and help support our programs. Bring your donation to the party!



Continued on next page

Map to The Elks Lodge

1475 Creekside Drive
Walnut Creek, CA 9459

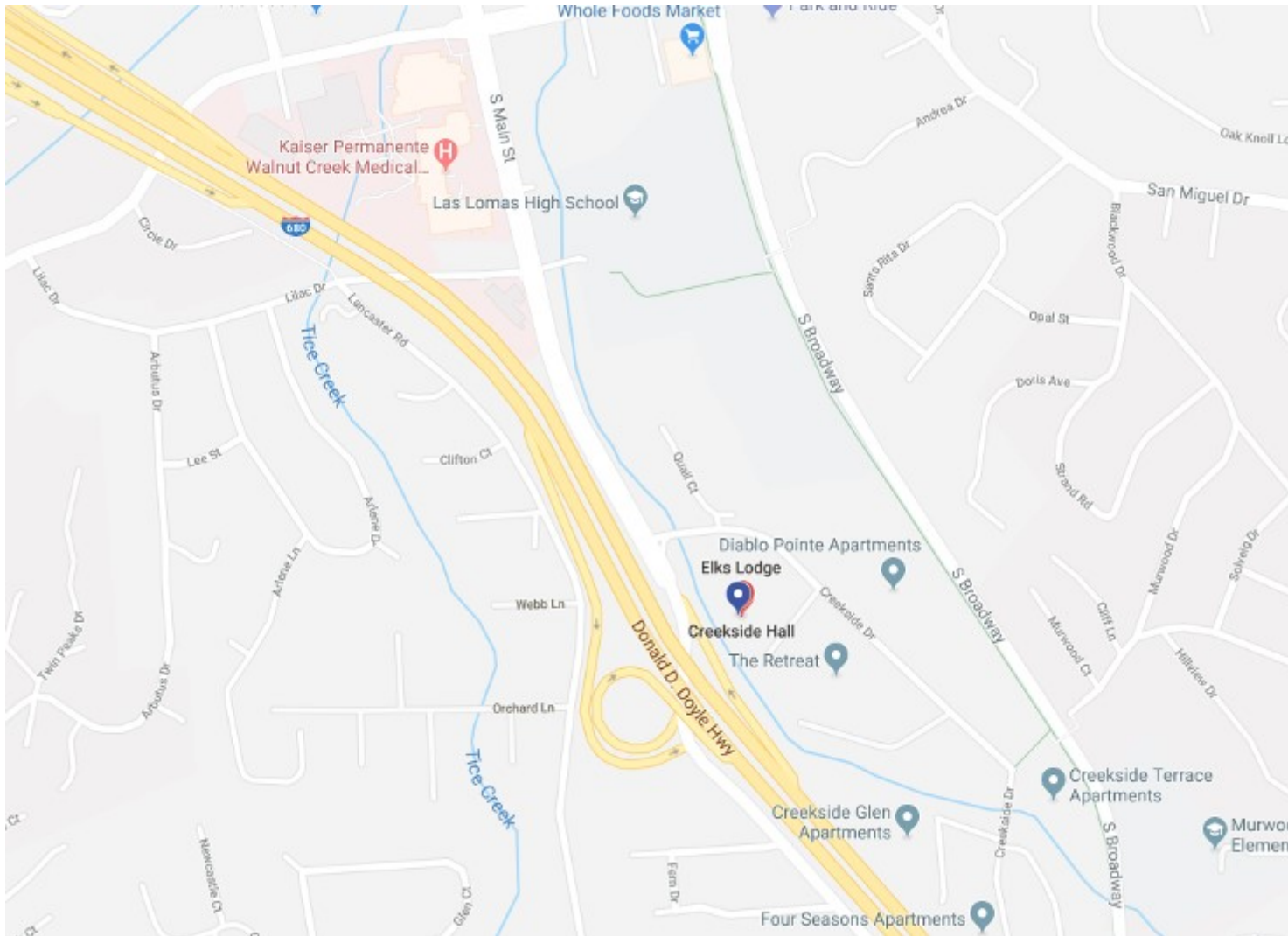

This year it is our pleasure to thank the corporate donors and businesses that support BAWA. Please remember these businesses when shopping for your turning needs:



Continued on next page

Silent Auction

We will have all kinds of interesting items in the silent auction, including some terrific blanks of Maple showing the effects of Mistletoe with spalting, Acacia and spalted Bay.



Come to the party and place your bids!

Attention BAWA members who shop on Amazon.com

BAWA is always looking for ways to generate funds to improve our Club. BAWA recently registered with Amazon's program to support charitable organizations, AmazonSmile. It is an easy, no cost way for our Club to benefit from your Amazon.com shopping expenditures.

AmazonSmile is a simple and automatic way for you to support your favorite charitable organization; **BAWA!** When you shop at smile.amazon.com, you'll find the exact same products, prices, and Amazon Prime benefits as Amazon.com, with the added bonus that Amazon will donate .5% of the purchase price to BAWA.

Here's how it works:

To shop at AmazonSmile simply go to smile.amazon.com from the web browser on your computer or mobile device. On your first visit to AmazonSmile, you need to designate BAWA to receive donations before you begin shopping. We are one of the almost one million charitable organizations registered with Amazon Smile. From then on when you enter Amazon through <https://smile.amazon.com/> every eligible purchase you make will result in a donation to BAWA.

You may want to bookmark the AmazonSmile URL to your desktop or mobile device to insure that you don't end up at the standard Amazon portal, thus bypassing benefit to BAWA.

If you haven't already done so, please consider registering with AmazonSmile and designating BAWA as your beneficiary. And encourage your friends and family to do likewise! We look forward to updating membership monthly on donations from this unique program.





BAY AREA WOODTURNERS ASSOCIATION

A CALIFORNIA NONPROFIT CORPORATION
LOCAL CHAPTER AAW

Club Meetings

Meetings are the 2nd Saturday of each month unless otherwise noted.

8:30 doors open for setup, use store and library, swap ideas, view displays

9:00—12:30 meeting and demo

Meetings will be held at the PHEC Woodturning Center, 1 Santa Barbara Road, Pleasant Hill, CA.

See bayareawoodturners.org/ for directions and club information.

BAWA Officers Meeting -

Officer meetings are open to all members. Contact John Cobb at: president@bayareawoodturners.org if you would like to be on the agenda.

2018 – 2019 Event Schedule

Dec 8th	Holiday Party 11:00-2:30
Jan 12th 2019	Jim Rodgers 8:30-12:30
Feb 9th	Mike Mahoney A Remote Demo 8:30-12:30
Mar 9th	Dave Fleisig Epoxy Ring Embellishments 8:30-12:30
Mar 15-17th	Oregon Woodturning Symposium Albany, OR
Apr 13th	Charlie Saul Turnings with Carvings & Piercings 8:30-12:30

The Bay Area Woodturners Association is a local chapter of the American Association of Woodturners. Our purpose is to provide a meeting place for local turners to share ideas and techniques and to educate the general public regarding the art of turning. The Association usually meets the second Saturday of each month. The Association periodically sponsors exhibitions and demonstrations by local and internationally known turners.

President
John Cobb
president@bayareawoodturners.org

Vice President
Dave Bentley
vp@bayareawoodturners.org

Secretary
Anna Duncan
secretary@bayareawoodturners.org

Treasurer
Peter Wolff
treasurer@bayareawoodturners.org

Member at Large
Kim Wolfe
memberatlarge@bayareawoodturners.org

President Emeritus
Joel Albert
cobbemail@gmail.com

Pleasant Hill Adult Education (PHAE) Liaison
Jim Rodgers
Jlrogers236@comcast.net

Librarian
Cindy Navarro
librarian@bayareawoodturners.org

Membership
Hugh Bevin-Thomas & Karen Rice
membership@bayareawoodturners.org

Store Manager
Richard Kalish & Michele Freeze
storemanager@bayareawoodturners.org

Webmaster
Jeff Tanner & Greg Ketel
webmaster@bayareawoodturners.org

Newsletter Editor
Louie Silva
newslettereditor@bayareawoodturners.org

Video Coordinator
Dave Bentley, Larry Batti & Ed Steffenger
videocoordinator@bayareawoodturners.org

Woodmeister
Steve Griswold
woodmeister@bayareawoodturners.org

Educational Coordinator
Jan Blumer
educationalcoordinator@bayareawoodturners.org

Pro Demonstrator Liaison
John Cobb
Cobbemail@gmail.com

Staff Photographer
Rick Dietrich

Social Coordinator
TBA

December Meeting: Jim Rodgers Presents Transitional Vessels

Our lead off presenter for January, Jim Rodgers, will be presenting Transitional Vessels. Transitional Vessels include one or two segmented rings with a body of solid hardwood. These projects can be made out of scrap woods you have lying around your shop. They are also a good way to use up old pen blanks and laminates that you have in inventory.



The process follows standard construction on two faceplates. Often the feature ring when made can be cored and split into two rings then used in two places on the vessel. Wood used for the bottom and tops of the vessels may vary in color from the wood used in the body of the piece. The artist making the vessel may add items like veneers or colored woods to the rings.

Jim is a master at making these vessels. If you have wandered around the woodturning classroom and found the movable shelving unit in the back, you have seen Jim's transitional vessels. The beauty of each one is unique, colorful and eye catching.

Before you throw out some of that leftover wood that you weren't sure you would ever use, mark the dates of this meeting on your calendar so Jim can show you this particular art form and a use for that leftover wood. In Jim's book, "The Fundamentals of Segmented Wood Turning", there is a complete section on Transitional Vessels. As in all of his books on woodturning, the directions are clear, concise and easy to follow.

Please join us for Jim's presentation. I think you will find it interesting and informative and a great way to make some beautiful pieces of wood art.

Every year Jim starts us out in January with an informative and relevant subject. Over the years he has taken us back to the basics of woodturning and found ways to correct those little annoying problems that we run into when we are turning in our shops. He makes the path we follow in woodturning a little less bumpy and very enjoyable.

There are several new videos on the club website that are about 15 to 20 minutes long that feature Jim demonstrating specific woodturning tools, tool usage, sharpening those tools and the way a tool with the same name can appear different and be used in unique ways. If you have time, please look for the videos. There are currently three under the Members Only Section, Meeting Videos heading. They cover the Spindle Roughing Gouge, the Skew, the Shallow Fluted Spindle Gouge and the Parting Tool.

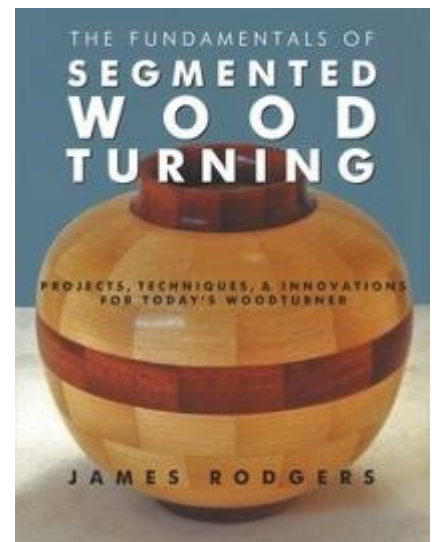
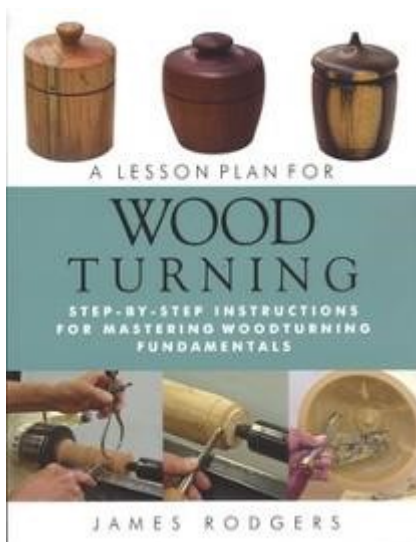

2018 Election Results

All the ballots have been counted, hanging chads and all, so the Board certified the election of our BAWA officers for 2019.

President: Kim Wolfe
Vice President: Dave Bentley
Treasurer: Claudia Foster
Secretary: Peter Wolff
Member at Large: Anna Duncan



Congratulation and thank you for volunteering your time to the continued success of BAWA.

President's Chatter *November 2018*



At the November Meeting we elected the new BAWA Board that will navigate the club in 2019 and hopefully through 2020. What is exciting to see is that Kim Wolfe, Dave Bentley, Claudia Foster, Peter Wolff and Anna Duncan are all relatively new to BAWA and they will bring in fresh ideas and new perspectives to running the club. The world of woodturning is constantly changing and the demographics and interests of our members is also evolving. I strongly believe we have the right group to make BAWA's program even better.

I do want to thank Dave, Peter, Kim and Anna for all their time and effort over the past year in helping to deliver a great schedule of meetings for BAWA's members. In addition, a huge thank-you to all the club officers who help make each meeting run. Having the newsletter, store, library, membership table, wood raffle, AV system and high school program all happen with a group of great volunteers. We all enjoy having these club features, it is definitely a significant part of what makes BAWA so successful.

I have to say being involved in running BAWA over the years has opened up many unexpected opportunities and definitely pushed me to become a better turner. The club always needs an extra hand for a one-off job or an hour or two each month. It's a great way to get involved without a huge commitment. Talk to any Board member or club officer and give it a try.

This Saturday, we have potentially the best ever BAWA holiday party. Kim and Anna have done a fantastic job organizing the venue, food, decorations, raffle and auction. This year we are trying an instant gallery, so please pack along a piece or two to display. Whether you are a novice or advanced turner - bring something you are proud to have made.

I look forward to seeing everyone on Saturday.

Enjoy the holidays.

John Cobb

Tips and Techniques

It is that time of year when everyone get anxious and nervous about what they can get the people they care about for a present.

Since we have the ability to make things we can let go of that anxiety.

Making things for people should be given thought about who they are and what they might like, without asking. It should be something that surprises them and at the same time challenges you in your skills and creativity.

At this time of year we are bombarded by commercials, radio commercials and the constant message to buy, buy, buy.

DON'T FALL FOR IT!

Making something for someone is full of thought, caring and love. It is a way to express all of that by the act of creating something special. Being special doesn't mean that it has to be elaborate or flashy, it just has to be full of thought.

Often it is a simple thoughtful gift made with love that we prize the most. Let your creativity guide you in your process. Look and listen to see something that you might make for those around you. It may be something you never thought of but with your observations you just might find our something you did not know.



by Cindy Navarro

Try something new and different, use your skills, get creative, but don't forget to have fun and fill your work with your love and caring and it will shine through.

Book Review

Watching DVD's and reading books to review is fun for me, but it is time consuming and I haven't had much time this month so I am not doing a review.

However, I would like to propose a challenge to all of you. I would like to invite each of you to give me a suggestion of a DVD or book that you would like me to review, as I sometimes cannot think of what to review.

I would also like to challenge you to submit a review of any book or DVD that you think other members would enjoy and benefit from seeing or reading.

Have a good party, I will miss attending it this year. I will be in Florida at the Florida School of Woodwork taking a week long class.

Happy Holidays to all of you and enjoy time with family and friends.



John Cobb Demonstrates Turning a Hollow Form

John showed us his talents and expertise in picking wood when on November 10, 2018 he showed us how to turn the perfect hollow form. As an expert in the creation of Hollow Form art and a teacher at the Mt. Diablo Adult Education School of Woodturning, he showed us his unique perspective on the wood, design and creation of his Hollow Form art.



As he began his presentation with a piece of harvested wood, all went smoothly through his creative process as he taught us how to create a hollow form. From the form to the way the wood is placed on the lathe for the best possible design is his forte. His time as a teacher and professional woodturner showed as he quickly reduced his wood blank to a Hollow Form. Personally, turning a large number of hollow forms showed how repetition and constant thought in the way he used his woodturning tools created a piece that needed very little if any sanding.

The one thing I have always admired about John is his success in becoming a professional woodturner. A goal that many of us can only dream about.

He has also devoted a lot of personal time to keeping our club one of the best clubs in the country. He is a face recognized by professional woodturners and his peers at the conventions and by his many customers. He is also a man that has devoted 3 years to the club as president mixing thoughtfulness with good management style to keep us all at the top of our game.

I hope you will also be at the end of the year party for the “BAWA Year in Review 2018” presentation. The expertise in the club and the accomplishments of this year reflect warmly on our outgoing president.



Blank mounted between centers



Rounder & rounder



Forming the tenon



Shaping the bottom



Hollowing commences

The Creation of a Hollow Form



Proper stance for hollowing



Redwood jam chuck in place



HF reversed in jam chuck



‘This is it folks.’



Top of finished piece

November Show and Tell



Ron Kersey-
Sam Maloof Style Rocker



Chuck Cottril-
Hollow Forms



Jay Holland-
Vases



Vern Stovall-
Carved Hollow Forms



Gary Bingham-
Hollow Form & Platter



Jean-Louis Meynier-
Hollow Forms

Continued on next page

*November Show and Tell
Cont.*



David Fleisig-



Jerry Jakubowski-
Bottle Stopper & Coasters



David Nelson-
Sycamore Bowl



Tim Kennedy-
Bowl



Steve Smyers-
Vase



Dave Bentley-
Hollow Form & Leaf

Continued on next page

*November Show and Tell
Cont.*



John Cobb-
Massive Hollow Form



Steve Griswold-
Hollow Form

AAW VIDEO: FLICK OF THE WEEK

In this video, Yuval Lahav demonstrates how to make a holiday ornament inspired by Malcolm Tibbitts.

Copy link below:



<https://www.youtube.com/watch?v=JV8VUHXxYz8&feature=youtu.be+Woodturning+2017+Christmas>



Sent from Above

By Nick Cook

It just takes one good turn for these Christmas Angels to earn their wings.

While serving on the board of a community arts organization, I agreed to create a turned wooden angel for the benefit "Angel Show." Even though that was a dozen years ago, I find joy in turning this project. Hope you'll find as much pleasure turning these angels as I have.



1 Rough out between centers with a 1 1/4" roughing gouge. With a 3/8" bedan tool, cut a 2" x 3/8" tenon (for fitting the blank into a scroll chuck) in one end.



2 Mount the body in a scroll chuck, using the tenon. Shape the body first, then hollow the interior with a 1/2" spindle gouge. Hollow the interior to reduce weight—just in case someone wants to use the angel as an ornament. To mount the body with a scroll chuck in the next step, turn a spigot on the inside of the body.

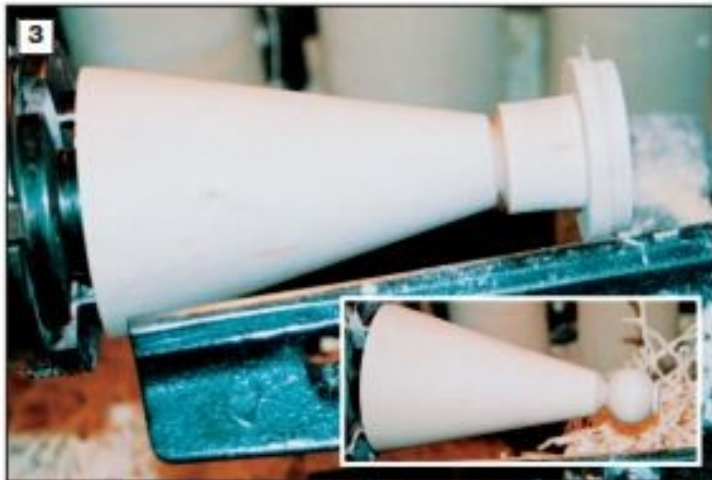

3 To turn the head, reverse the blank, then expand the scroll chuck into the spigot. This allows you to remove the tenon and shape the angel's head to about a 1" diameter (inset).

Material and tools

For this project, I use 3" squares of ash or hard maple, commonly sold as baseball bat blanks, in 36"-lengths. If you cannot find blanks like this locally, try www.hardwoodweb.com.

Of course you can use other material as well. Pine and poplar are both inexpensive and well-suited if you paint the finished product.

For tools, I recommend having these sharpened and ready: 1 1/4" roughing gouge, 3/8" bedan tool, 3/8" spindle gouge, 3/8" or 1/4" deep-fluted bowl gouge.

The project also requires a scroll chuck.

Turn the angel's body

Cut the squares into lengths of 4", 6", 8", and 10" or select lengths to suite your own needs. Turn the blanks between centers with a 1 1/4" roughing gouge and form a tenon approximately 2" x 3/8" at one end to fit a scroll chuck (Photo 1).

After mounting the blank in the scroll chuck, true up the opposite end and turn a cone to about 1 1/2" of the tenon. Next, hollow the blank to match the exterior shape, leaving the walls about 3/16" thick (Photo 2).

Several tools are suitable for hollowing. When I start in the center and work toward the final wall thickness, I've had good luck with a 3/8" spindle gouge. This step removes most of the weight, which allows the angel to be used as an ornament or tree topper.

For turning the top of the angel, leave a short spigot inside the cone to accept the expansion jaws of the scroll chuck.

Remove the blank from the chuck and remount at the opposite end. This will allow you to remove the tenon and shape the angel's head (Photo 3). For this step, I prefer a 3/8" or 1/2" spindle gouge ground to a fingernail shape; the long fingernail grind lets me produce fine details. I turn the head to about 1" diameter.

Sand the angel by stepping through 150-grit, 180-grit, and finally 220-grit sandpaper.

Finish decisions depend on wood species and personal taste. For ash, I apply a white

Continued

pickling stain followed by a coat of clear satin lacquer. Allow to dry.

An angel gets its wings

No angel can fly without wings. For turned wings, I cut $5/4" \times 4"$ ash into rounds approximately $3 1/2"$ in diameter.

Draw a line through the center in line with the grain direction. Next, drill two holes in the wing disc. The first is $3/4"$ diameter and it is drilled $5/8"$ from the edge on the line through the center. The second hole is $1 1/8"$ diameter and is drilled $3/4"$ from the opposite edge of the disc, also on the centerline. Refer to the illustration *opposite*. To reduce tearout, use Forstner bits at a drill press (Photo 4). Then bandsaw the wing discs (Photo 5).

I use a screw chuck with a spacer to mount the disc on the lathe (Photo 6). With a $1/4"$ or $3/8"$ bowl gouge, turn the first side just as you would shape the bottom of a bowl or shallow plate. Leave a small flat surface at the center to remount the piece on a glue block.

With medium CA glue, attach the wing blank to a $2" \times 1"$ waste block mounted in the scroll chuck. I use solid maple or poplar for my waste blocks.

After the CA sets, turn the back side of the wings into a dish-like shape, leaving the wall thickness just under $1/8"$ (Photo 7). Either a $3/8"$ or $1/4"$ deep-fluted bowl gouge is perfect for the task. To avoid the gouge catching in the wing holes, turn at a speed in the 1,800 range.

Use extra care sanding the holey wings, stepping through 150, 180 and 220 grits. After sanding is complete, apply finish to match the angel's body.

Before separating the dish from the waste block, turn a $1/4" \times 1/4"$ tenon on the bottom side (Photo 7 inset). The tenon will fit into a $1/4"$ -diameter hole drilled into the back of the angel body. For this drilling step, I prop the angel with a sand bag (Photo 8).

Before attaching the wings, use a bandsaw, scrollsaw, or coping saw to cut a space in the top and bottom holes to give the appearance of wings (Photo 9 and pattern *opposite*).



4 Before cutting circles for angel wings, mark a centerline on a $5/4" \times 4"$ wide maple or ash stock. Draw a $3 1/2"$ circle and mark center for the $3/4"$ and $1 1/8"$ holes. Then bore the holes with a Forstner bit as shown.



5 After boring the holes, bandsaw the $3 1/2"$ -diameter wing discs.

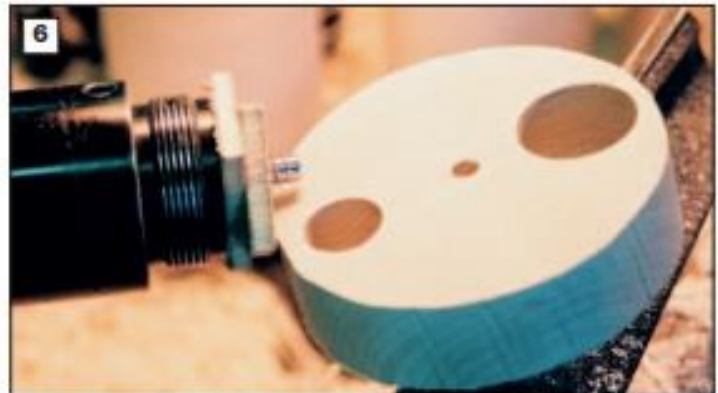

6 To turn the outside of the angel wings, use two $1/4"$ plywood spacers to reduce the length of the screw penetration into the $5/4"$ stock.



7 Use a $3/8"$ bowl gouge to turn the interior of the bowl-shaped wings. When finished, turn a $1/4"$ tenon (inset) on the back side of the wings. The wings attach to the body with the tenon.

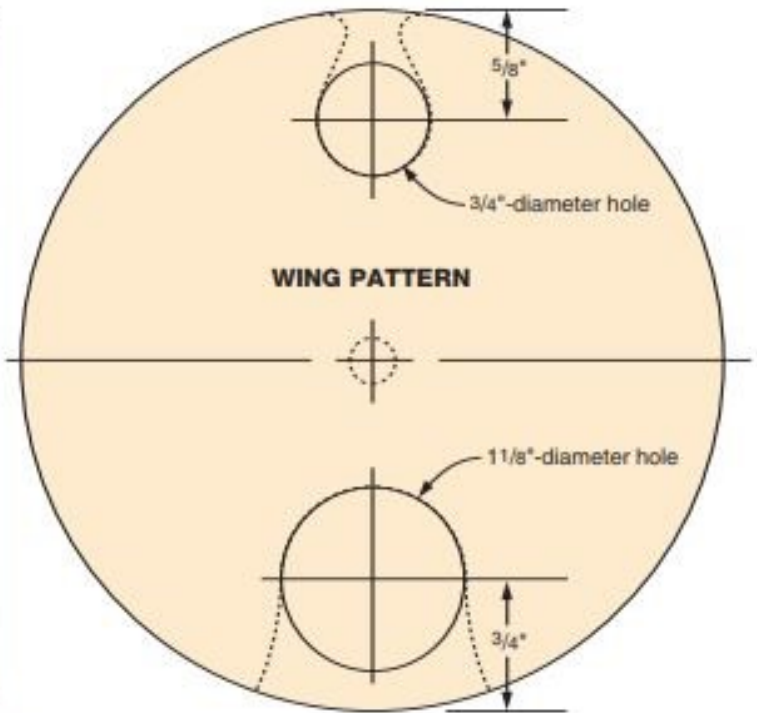
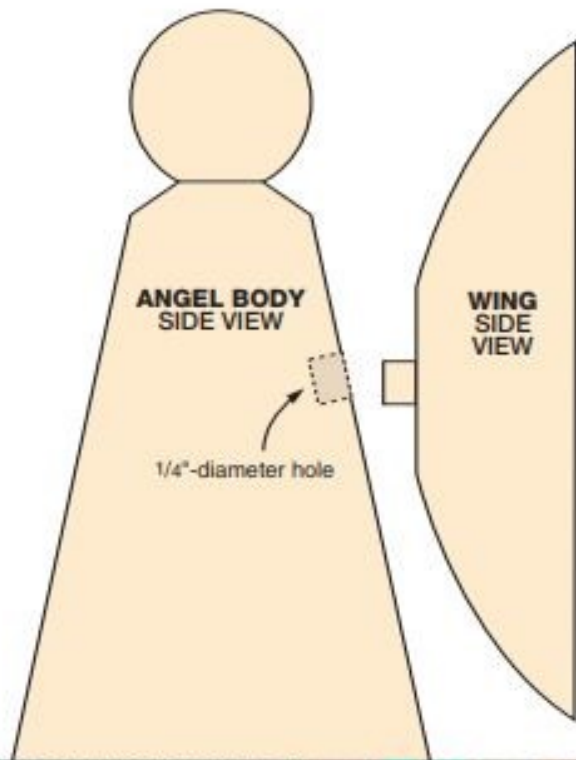

Using the pattern above as reference, cut the final wing shape with a bandsaw, scrollsaw or coping saw.



Prop and support the angel on a sandbag, then drill a 1/4" hole in the back of the body to fit the wing tenon. Use your hand to prevent the angel from rolling during the drilling procedure.

Wing options

Another wing style involves shaping safety wire or brass wire into a figure eight. Once twisted together, you can push the center of the wire into a small hole in the back of the angel.

Need a third option? With metal sheers, cut wings from brass, aluminum or even pewter. Pewter—the softest and easiest to work—is the most expensive of the three.

Don't forget the halo

I have never actually had my own halo, so I really don't know how to describe it. There are two styles of angel halos shown on page 44. The angel in the background has a halo turned as part of the head. The foreground angel has a 3/4"-diameter turned ring added to the head.

You also can bend a halo from safety wire or brass wire.

Nick Cook (nickcook@earthlink.net) is an American Woodturner contributing editor. He lives in Marietta, Georgia.

Articles courtesy of AAW

Oregon Woodturning Symposium

invites you to join us at our event

Oregon Woodturning Symposium

March 15-17, 2019

Linn County Expo

The Oregon Woodturning Symposium returns to the Linn County Expo Center in Albany, OR on March 15, 16 and 17, 2019. This edition features demonstrations by *Richard Raffan, Glenn Lucas, Michael Hosaluk, Jimmy Clewes, Sam Angelo, Cynthia Gibson, Art Leistman, Jim Rodgers, Seri Robinson, Curtis Seebeck and Dave Schweitzer*. Go to www.oregonwoodturningsymposium.com for more information and to register. Or contact us at oregonwoodturningsymposium@gmail.com. The always outstanding Instant Gallery and Vendor Show are open to the public. We hope to see you in Albany!

To Register for the Symposium, Go To:

www.oregonwoodturningsymposium.com

We look forward to seeing you in March!



BAWA Meeting Video's

Just wanted to make sure you know what videos are available on the BAWA website. We have seven videos that were produced in 2017, you can find them in the list below. In 2018 we have 12 videos that have already been produced, they range from videos of our guest speakers, to three short training videos highlighting Jim Rodgers covering the use, sharpening and reason for each tool and a video on the Southwest Association of Turners Convention given to the club by Jean-Louis Meynier. There is one video (Sam Angelo's presentation) that is still under construction and two or three more that will occur before the end of the year.

You can find all the videos on the main page of the BAWA website, under the Members Section, click on Meeting Videos and the video list comes up. Once you find the video you want to see, just click on the video and you will be taken to the video for playback and viewing.

Videos From 2017

[May 2017 Mike Mahoney](#)

• [Part 1](#)

[Part 2](#)

[June 2017 Brad Adams](#)

[September 2017 Kalia Kilban](#)

[November 2017 Carl Jacobson](#)

[December 2017 BAWA Christmas Party](#)



Videos From 2018

[January 2018 Jim Rodgers](#)

[February 2018 Karen Freitas](#)

[March 2018 Rudy Lopez](#)

[April 2018 John Jordan Part I](#)

[April 2018 John Jordan Part II](#)

[May 2018 Robert Whitworth](#)

[June 2018 Jay Holland](#)

[Jim Rodgers - Lesson 1 The Spindle Roughing Gouge](#)

[Jim Rodgers - Lesson 2, The Skew](#)

[Jim Rodgers - Lesson 3, The Shallow Fluted Spindle Gouge and Detail Gouge](#)

[Photos of the 2018 Southwest Association of Turners SWAT](#)

Photo's by Jean-Louis Meynier

September 2018 - Sam Angelo, The Wyoming Woodturner **(Under Construction)**

October 2018 - Bob Nolan

November 2018 - John Cobb **(Coming in Nov.)**

December 2018 - BAWA Year in Review 2018 **(Coming in Dec.)**



The Board and the Video Staff hope you enjoy.

Dave Bentley

Happy
Holidays!